



**BEERBLAST™ 7/14KPH
& N2-GEN™ 7/14KPH
O&M MANUAL**

Revision 1
Date 06/13/16



VERSION HISTORY

Revision #	Implemented By	Revision Date	Approved By	Approval Date	Reason
0	James Nguyen	12/15/14	J. Nguyen	12/15/14	
1	James Nguyen	6/13/16	J. Nguyen	6/13/16	

-----Notes Page-----

TABLE OF CONTENTS

1 INTRODUCTION	6
1.1 Purpose.....	6
1.2 Audience.....	6
1.3 Important Information.....	6
2 SAFETY GUIDELINES.....	7
2.1 General.....	7
3 SYSTEM DESCRIPTION.....	8
3.1 Key Features	8
3.2 Specifications (BeerBlast™ 7KPH / N ₂ -GEN™ 7KPH)	9
3.3 Specifications (BeerBlast™ 14KPH / N ₂ -GEN™ 14KPH)	9
3.4 System Operations	10
4 PRODUCT INSTALLATION.....	11
4.1 Unpacking and Preparation (BeerBlast™ 7KPH / N ₂ -GEN™ 7KPH).....	11
4.2 Unpacking and Preparation (BeerBlast™ 14KPH / N ₂ -GEN™ 14KPH).....	12
4.3 Electrical Requirements.....	13
4.4 Mounting (BeerBlast™ 7KPH / N ₂ -GEN™ 7KPH).....	13
4.5 Installation (BeerBlast™ 7KPH / N ₂ -GEN™ 7KPH)	15
4.6 Gas Connection (BeerBlast™ 7KPH / N ₂ -GEN™ 7KPH).....	18
4.7 Installation (BeerBlast™ 14KPH / N ₂ -GEN™ 14KPH)	20
4.8 Nitrogen Cylinder Back-Up (BeerBlast™ 7/14KPH / N ₂ -GEN™ 7/14KPH).....	22
4.9 Start-Up Procedures (BeerBlast™ 7/14KPH / N ₂ -GEN™ 7/14KPH).....	22
4.10 Checking for Leaks	23
4.11 Access Controls.....	24
4.12 Starting the System	24
4.13 Stopping the System.....	24
5 SYSTEM USAGE	25
5.1 Instructions	25
5.2 Alarm Notification.....	25
6 SYSTEM MAINTENANCE.....	26
7 KEY CONTACTS.....	28
8 FAQs	28
8.1 Power Issues	28
8.2 Pressure Issues	28
8.3 Gas Leaks.....	29
8.4 Temperature Issues: Very Common Issue	29
8.5 BlastOff™ - Leak Detection System:	29
APPENDIX A: WARRANTY	30

-----Notes-----

1 INTRODUCTION

1.1 PURPOSE

The BeerBlast™ 7/14KPH / N₂-GEN™ 7/14KPH provide an economical, precise means of supplying mixed beer gas to “push” the beer to the tap within restaurant and bar establishments. Beer brewers have established recommended Carbon-Dioxide (CO₂) and Nitrogen (N₂) mixed gas ratios to protect the kegged product quality, eliminating over-foaming or under-carbonation, while increasing the keg life. Precise mixed beer gas lowers operational costs, increases yields/profits, and ultimately provides a higher level of customer satisfaction. This system can also be used for wine or specialty mixed drink dispensing systems.

South-Tek System's line of BeerBlast™ 7/14KPH / N₂-GEN™ 7/14KPH products consist of an internal a) N₂ generator, b) compressor, and c) CO₂ /N₂ dual output gas blender (the N₂-GEN™ 14KPH does not come with a gas blender). Since air is comprised of ~79% N₂ we simply and cost-effectively separate the N₂ from the air. Nitrogen is an inert gas (non-combustible), which is even used to package food products for increased shelf life. The N₂ is “generated” by our pressure swing adsorption (PSA) technology, where compressed air cycles back and forth between two beds. As needed, the high purity N₂ is then forwarded to the integral McDantim™ dual output gas blender (only in the BeerBlast™ 14KPH and 7KPH model) which precisely blends the N₂ with the CO₂ from the restaurant/bar's in house storage cylinder/tank. The standard CO₂ /N₂ blends available are 60% / 40% and 25% / 75%. The blends are accurate to within 2%. Custom CO₂ /N₂ blends are available if desired.

**The installer and the user should read this manual in its entirety.

1.2 AUDIENCE

This manual is intended for Installer/Restaurant/Bar Operator/Supervisory Staff and should be read in its entirety prior to operation.

Please contact your local Beer Gas provider for any operation and maintenance first prior to contacting the manufacturer.

1.3 IMPORTANT INFORMATION

Before personnel attempt to service the unit, ensure the power switch has been turned to the off position, and then disconnect the unit's external power cord from the building electrical power supply if possible. Always follow specific manuals from STS when servicing your system.

The BeerBlast™ 7/14KPH / N₂-GEN™ 7/14KPH produces a gas blend of Carbon Dioxide (CO₂) and Nitrogen (N₂) at a low flow rate, which quickly dissipates into the air. CO₂ and N₂ gases are not poisonous but they should not be directly inhaled, since in high concentrations, they can cause asphyxiation. **Ensure that the unit is installed within a well-ventilated room, one that is not sealed off from normal living space air changes.**

All personnel involved with installation, operations, and maintenance of the BeerBlast™ 7/14KPH / N₂-GEN™ 7/14KPH must follow safe working practices, OSHA, and local health/safety code regulations during the installation, operation, and maintenance of the unit.

2 SAFETY GUIDELINES

2.1 GENERAL

Correct use of the BeerBlast™ 7/14KPH / N₂-GEN™ 7/14KPH is important for your personal safety and for trouble-free functioning of the BeerBlast™ 7/14KPH / N₂-GEN™ 7/14KPH. Incorrect use can cause damage to the BeerBlast™ 7/14KPH / N₂-GEN™ 7/14KPH / 7KPH or can lead to incorrect gas supply.

The BeerBlast™ 7/14KPH / N₂-GEN™ 7/14KPH produces a gas blend of Carbon Dioxide (CO₂) and Nitrogen (N₂) at a low flow rate, which quickly dissipates into the air. CO₂ and N₂ gases are not poisonous but they should not be directly inhaled, since in high concentrations, they can cause asphyxiation. **Ensure that the unit is installed within a well-ventilated room, one that is not sealed off from normal living space air changes.**

All personnel involved with installation, operations, and maintenance of the BeerBlast™ 7/14KPH / N₂-GEN™ 7/14KPH must follow safe working practices, OSHA, and local health/safety code regulations during the installation, operation, and maintenance of the unit.

Warning:

- This manual must be read in its entirety to installing and operating the BeerBlast™ 7/14KPH / N₂-GEN™ 7/14KPH to prevent accidents and damage to the BeerBlast™ 7/14KPH / N₂-GEN™ 7/14KPH.
- Contact your supplier if you detect a problem that you cannot solve with this manual.
- Only use the BeerBlast™ 7/14KPH / N₂-GEN™ 7/14KPH in accordance with its designed purpose.
- Only service-engineers, that are qualified to work on electric and pneumatic equipment, are allowed to do the installation, maintenance and repairs. Unqualified people are not allowed to repair the equipment.
- Do not tamper or experiment with the equipment or exceed the technical specifications

3 SYSTEM DESCRIPTION

3.1 KEY FEATURES

The BeerBlast™ 7KPH and 14KPH / N₂-GEN™ 7KPH and 14KPH key features include the following:

- Air compressor
- Air Filters
- Programmable Logic Controller (PLC)
- Pressure Swing Adsorption Beds
- Safety Relief Valves
- N₂ Storage Tank
- Automatic Pressure Cut-in/Cut-out
- McDantim™ dual output gas blender (only in BeerBlast™ 7KPH and 14KPH model)
- STS Patented Blast-Off (optional)

Air Compressor:

The air compressor is designed internally to the cabinet and features engineered dampening system to reduce vibration and noise throughout the cabinet. It is an oil-less compressor with a pre-filter attached to the air input. The recommended replacement on the pre-filter is 1000 run hours or 1 year (whichever comes first). Dirtier environments may be required to be changed out more frequently. Consult your supplier for a different filter maintenance schedule if you are installing the generator in dirty environment.

Air Filters:

The generator has two filters after the air compressor: the particulate and coalescing. The Particulate has a 5 micron filter that will catch any of the larger particles. The Coalescing has a 0.1 micron filter that will catch the remaining smaller particles. Both filters feature and autodrain that will drain the water captured after the air compressor. The drain is plumbed to the outside of the cabinet where the end-user can then connect ¼” tubing and drain to a safe location.

Programmable Logic Controller (PLC):

There's an integrated PLC within the cabinet. It features smart and efficient coding to maximize the performance of the generator. It controls the timing and sequencing of the valves to effectively move compressed gas throughout the system. It also has a smart feature to automatically go into different “modes” based on the current run stages. It comes with a visual screen that will display run hours and alarms.

Safety Relief Valves:

Safety Relief Valves have been placed throughout the system for maximum safety. They are designed and put in place to minimize failure of other components. They all come with an ASME stamp.

N₂ Storage Tank:

A N₂ Storage Tank is housed inside the cabinet with manual ball valves and gauge. It is plumbed to an external manual ball valve so that the end-user will not have to do any plumbing within the cabinet.

Automatic Cut-In/Out:

The generator comes with a built in pressure switch that is tied into the PLC. This will provide a low voltage signal back to the PLC to put the system in a “Standby Mode” when the tank is full of Nitrogen.

McDantim™ dual output gas blender:

Precisely blends N₂ with CO₂ from the restaurant/bar's in house storage cylinder / tank. The standard CO₂ /N₂ blends available are 60% / 40% and 25% / 75%. The blends are accurate to within 2%. Custom CO₂ /N₂ blends are available if desired.

Patented Blast-Off Detection (optional):

The Blast-Off Leak Detection will provide the end-user with an alarm when it detects characteristics of a leak somewhere on the system. It will trigger an audible alarm, display it on the screen, and the end-user can tie into the dry contact so that the alarm can be relayed back to the Building Management System (BMS).

3.2 SPECIFICATIONS (BEERBLAST™ 7KPH / N₂-GEN™ 7KPH)

BeerBlast™ 7KPH / N ₂ -GEN™ 7KPH – Specifications	
Nitrogen Purity	99.8+%
Kegs per hour	7
Installation	Wall Mounted
Display	Hours/Power on/Operating
N ₂ Storage Pressure	60-70 PSIG
CO ₂ Gas Requirement	60-80 (min/max) PSIG
Available Blends	60/40 & 25/75 (CO ₂ /N ₂) *Factory Set
Blend Out Pressure	40-50 PSIG min
Cabinet Port Connections	1/4" NPT Female
Electrical	110-220V / 50-60Hz / 1Phase; 20 Amp Breaker
Compressor	Integral / Oil-Free
Ambient Temperature	40° to 85°F
Noise Level (dbA)	< 60 dbA
Size	12.75" W x 12" D x 27" H (Cabinet Dimensions)
Weight	Appx. 100 lbs

3.3 SPECIFICATIONS (BEERBLAST™ 14KPH / N₂-GEN™ 14KPH)

BeerBlast™ 14KPH / N ₂ -GEN™ 14KPH – Specifications	
Nitrogen Purity	99.8+%
Kegs per hour	14
Installation	Floor standing
Display	Hours / Run / Cool / Standby / Filter Alarm / BlastOff™
N ₂ Storage Pressure	60-75 PSIG
CO ₂ Gas Requirement	60-80 (min/max) PSIG
Available Blends	60/40 & 25/75 (CO ₂ /N ₂) *Factory Set
Blend Out Pressure	40-50 PSIG min
Cabinet Port Connections	1/4" NPT Female
Electrical	110-220V / 50-60Hz / 1Phase; 20 Amp Breaker
Compressor	Integral / Oil-Free
Ambient Temperature	40° to 90°F
Noise Level (dbA)	< 80 dbA
Size	26" W x 18" D x 59" H (Cabinet Dimensions)
Weight	Appx 265 lbs

3.4 SYSTEM OPERATIONS

The system has three standard run modes – Run, Cool, and Standby. When the power switch is turned on, the controller will automatically determine which mode to enter and will display the current run mode on the screen – “Run” in Green, “Cool” in Yellow, and “StdBy” in Yellow.

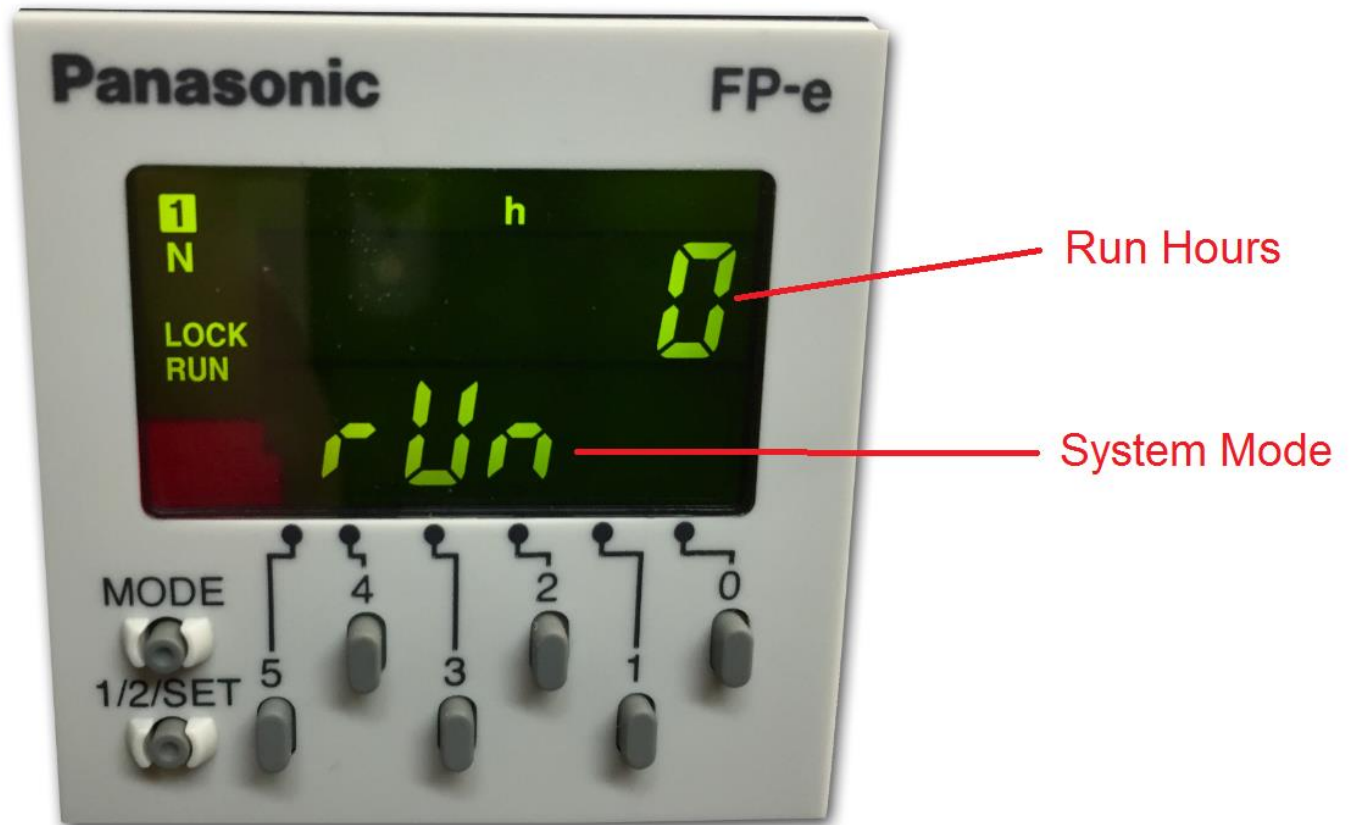

“Run” mode is when the BeerBlast™ 14KPH / N₂-GEN™ 14KPH is producing nitrogen and feed it to the storage tank. It will run through a couple cycles and then enter into a “Cool” mode for one cycle. This prevents the internal air compressor from overheating and over working. The system will automatically enter “Standby” mode when the tank is fully pressurized (65-75 psig). It will remain in “Standby” mode until the tank pressure falls 7-10 psig.

4 PRODUCT INSTALLATION

4.1 UNPACKING AND PREPARATION (BEERBLAST™ 7KPH / N₂-GEN™ 7KPH)

The BeerBlast™ 7KPH / N₂-GEN™ 7KPH's cardboard carton should be carefully opened and all parts should be inspected for damage upon receipt. Identify and verify that all parts listed on the packing list are present and undamaged. South-Tek Systems (STS) is not responsible for damages that have occurred during the shipping and handling of the BeerBlast™ 7KPH / N₂-GEN™ 7KPH. Any visual damages should be immediately documented and reported to the shipping company responsible. Then, contact STS at (888)526-6284 to assess the damages only after the shipping company has been notified.

Until Installation:

- Store the BeerBlast™ 7KPH / N₂-GEN™ 7KPH in a dry and climate controlled (60-80°F) room.
- Always keep BeerBlast™ 7KPH / N₂-GEN™ 7KPH in an upright position / or in box as shipped.
- Do not connect the AC power cable until this manual has been read completely and all connections are made as stated within.
- Keep all gas lines dry so moisture does not enter generator upon hookup.
- Never place/stack objects on top of the BeerBlast™ 7KPH / N₂-GEN™ 7KPH.

4.2 UNPACKING AND PREPARATION (BEERBLAST™ 14KPH / N₂-GEN™ 14KPH)

The BeerBlast™ 14KPH / N₂-GEN™ 14KPH will arrive in a wooden crate. Open the side noted, “Open this side”. Once the crate is opened, inspect all parts for any damage upon receipt. Take any pictures upon arrival of the crate, of damages done during shipping. Identify and verify that all parts listed on the packing list are present and undamaged. South-Tek Systems (STS) is not responsible for damages that have occurred during the shipping and handling of the BeerBlast™ 14KPH / N₂-GEN™ 14KPH. Any visual damages should be immediately documented and reported to the shipping company responsible. Then, contact STS at (888)526-6284 to assess the damages only after the shipping company has been notified.

Until Installation:

- The BeerBlast™ 14KPH / N₂-GEN™ 14KPH can be stored inside the wooden crate until installation. For extended storage of over a month, open and insert desiccant bags as needed to prevent moisture buildup.
- Store the BeerBlast™ 14KPH / N₂-GEN™ 14KPH in a dry and climate controlled (60-80°F) room.
- Always keep the BeerBlast™ 14KPH / N₂-GEN™ 14KPH in an upright position.
- Do not connect the AC power cable until this manual has been read completely and all connections are made as stated within.
- Keep all gas lines dry so you don't get moisture in the generator upon hookup.
- Never place/stack objects on top of the BeerBlast™ 14KPH / N₂-GEN™ 14KPH.

To remove the BeerBlast™ 14KPH / N₂-GEN™ 14KPH from the crate, unbolt the cabinet base from the crate. Carefully, lift the unit from the crate and set it on the floor. The use of a floor jack is advisable to move it to the final location. Once in place, unbolt the 4 colored bolts at the bottom of the cabinet.

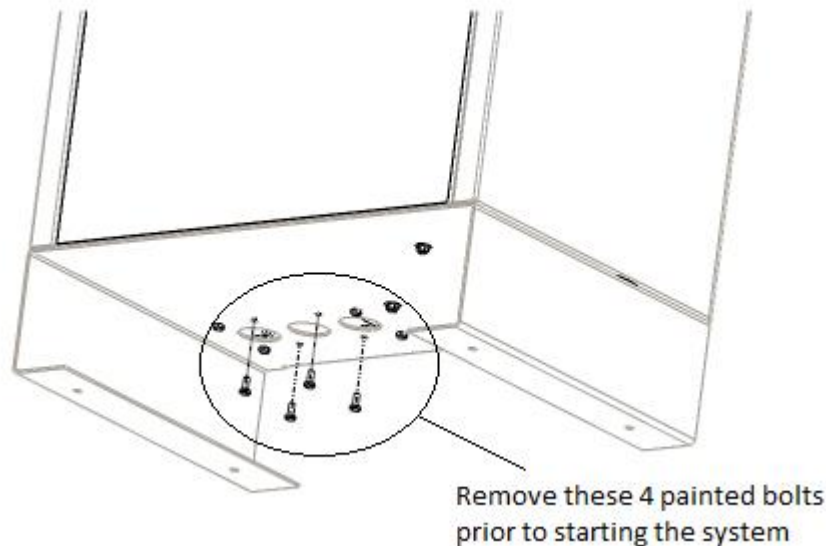

Carefully, break down the crate and store in a safe location in the case that it may need to be sent back to the factory for service.

4.3 ELECTRICAL REQUIREMENTS

The BeerBlast™ 7/14KPH / N₂-GEN™ 7/14KPH requires 110–220V / 50-60 hz / 1ph connection. It has a built in 20A circuit breaker and a standard 3-prong US power cord is provided for the electrical connection. The system is UL 508A ICP approved. Electrical schematic available upon request.

4.4 MOUNTING (BEERBLAST™ 7KPH / N₂-GEN™ 7KPH)

The BeerBlast™ 7KPH / N₂-GEN™ 7KPH can be mounted to a wall or placed on a floor. It is recommended that the BeerBlast™ 7KPH / N₂-GEN™ 7KPH be mounted to a weight-bearing wall that can support its weight as specified in Specifications (BeerBlast™ 7KPH / N₂-GEN™ 7KPH). If placed on the floor, it should still be fastened in place so that it cannot move due to vibration or damaged from falling over. The BeerBlast™ 7KPH / N₂-GEN™ 7KPH should always be installed indoors in an environment between 40° and 85° F in the upright position where it will not be damaged by water or moving equipment. Leave at least 6" on the left side of the cabinet for ventilation, but 36" is recommended for access to the control panel, tube/pipe connections, and the front cover. There is a ¼" OD tube drain port on the bottom right of the cabinet. This can be plumbed to the nearest site drain.

There is an optional mounting bracket kit (STS Part #: A05-TYP1-RD), that allows you to mount the system on a standard 16" wall stud width. Otherwise, use the mounting holes on the cabinet for mounting the BeerBlast™ 7KPH / N₂-GEN™ 7KPH securely and level, directly to the wall.

Optional Mounting Bracket Kit Procedures

1. All BeerBlast™ 7KPH / N₂-GEN™ 7KPH mounting holes and optional mounting bracket holes are for ¼" screws/anchors.
2. All brackets must be installed in orientation as shown to work correctly.
3. Install the cabinet-mounting brackets on the BeerBlast™ 7KPH / N₂-GEN™ 7KPH first with the bolts/lock nuts that are provided.
4. Locate the wall-mounting bracket. It is an 18" bracket without the rectangular cutouts and will need to be installed on the wall at the desired height and level. The bracket has 16" center to center holes so the unit can be mounted directly to studs. This bracket will need to be mounted per the diagram below using appropriate for your type of wall material (wood, sheet metal, masonry, etc....). Once the 18" bracket has been wall mounted, this will allow the 12" bracket that is fastened to the top flange of the cabinet a fixed anchor to hang from. See diagram as to how the angles are to be oriented on the back of the cabinet vs the wall.
 - a. Use the supplied nuts and bolts to attach the upper 12" bracket onto the top flange per the diagram.
 - b. Use the supplied carriage bolts and nuts to attach the 18" lower bracket to the bottom flange, don't overtighten the nuts yet. After installing the system, you may want to offset the bracket slightly, hence the rectangular slots.
5. Optional: if wall studs are not 16" center to center or you have the need to reinforce mounting area, a ½" or thicker plywood is recommended to be installed prior to hanging the system. Use best general practices to ensure that the wood and system will be secure at its full weight and remember that it will be vibrating from compressor running.
6. Once the mounting brackets are all in place, hang the BeerBlast™ 7KPH / N₂-GEN™ 7KPH cabinet from the top bracket making sure it is centered.
 - a. The cabinet should have at least 4" on either side for breathing/cooling purposes.
 - b. Do not install near heat source or where steam or water is present. Damage to system or bodily harm may result as well as voiding warranty.

Warning: Secure the BeerBlast™ 7KPH / N₂-GEN™ 7KPH to the wall at the top and bottom flanges. Failure to do so could cause damage or bodily injury.

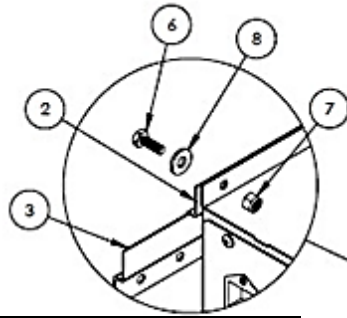

Item #	STS Part #	Description	Qty
1	BB™ 7KPH	Mini PSA	1
2	800-133	S-100/200 12" Mounting Bracket	1
3	800-134-B	S-100/200/400 18" Mounting Bracket	1
4	800-129	Type 1 Lower Wall Mount Bracket	1
5	Misc	0.250" -20 x 0.750" Carriage Bolt	2
6	Misc	0.250" -20 x 0.750" Hex Cap Screw	2
7	Misc	0.250" Nylock Nut	4
8	Misc	0.250" Flat Washer	2

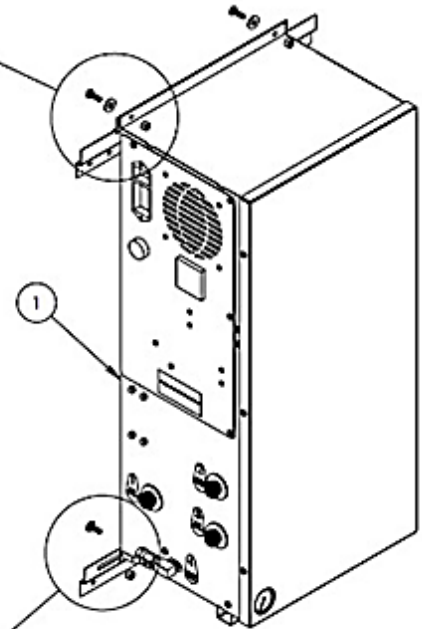

Carriage Bolt must be installed from the back side of bracket

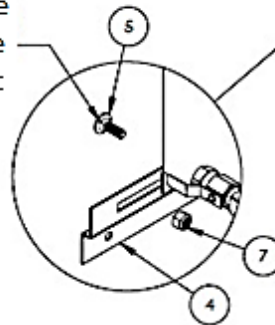

4.5 INSTALLATION (BEERBLAST™ 7KPH / N₂-GEN™ 7KPH)

The BeerBlast™ 7KPH / N₂-GEN™ 7KPH Mixed Gas Dispense System can be installed for one or multiple CO₂/ N₂ blends. It is necessary to use caution when working with pressurized gas, making sure that all fittings and gas lines are installed correctly. Always leak check every line before using the system.

Note: Line leaks will cause the BeerBlast™ 7KPH / N₂-GEN™ 7KPH to run excessively, shortening its life.

In most systems, the BeerBlast™ 7KPH / N₂-GEN™ 7KPH can supply two gas blends (of N₂ and CO₂) or a single Nitrogen output for N₂-GEN™ models. These lines can be split individually to provide the correct gas and/or blended gas to all of the beverage lines. Use only quality beverage tubing and fittings for all connections. Keep in mind the temperature and pressure requirements when selecting them.

Always install a valve (on/off) on each individual line. This will help with troubleshooting the system. Never detach a line with pressure on it before closing the valve; this could cause damage to the equipment or bodily injury. Also avoid depressurizing the keg at all costs; this will negatively affect the beer quality. Always shut off the valve and remove the tap from the keg before changing or servicing the gas lines.

Two condensate drains for the generator are located on the bottom right of the cabinet. It is the responsibility of the installer to plumb these drains to an area where standing water is trapped or a drain is located. Failure to do so can cause a slipping hazard on the floor below the generator.

If your system requirements are more involved, please consult your sales representative or equipment installer for a customized installation drawing.

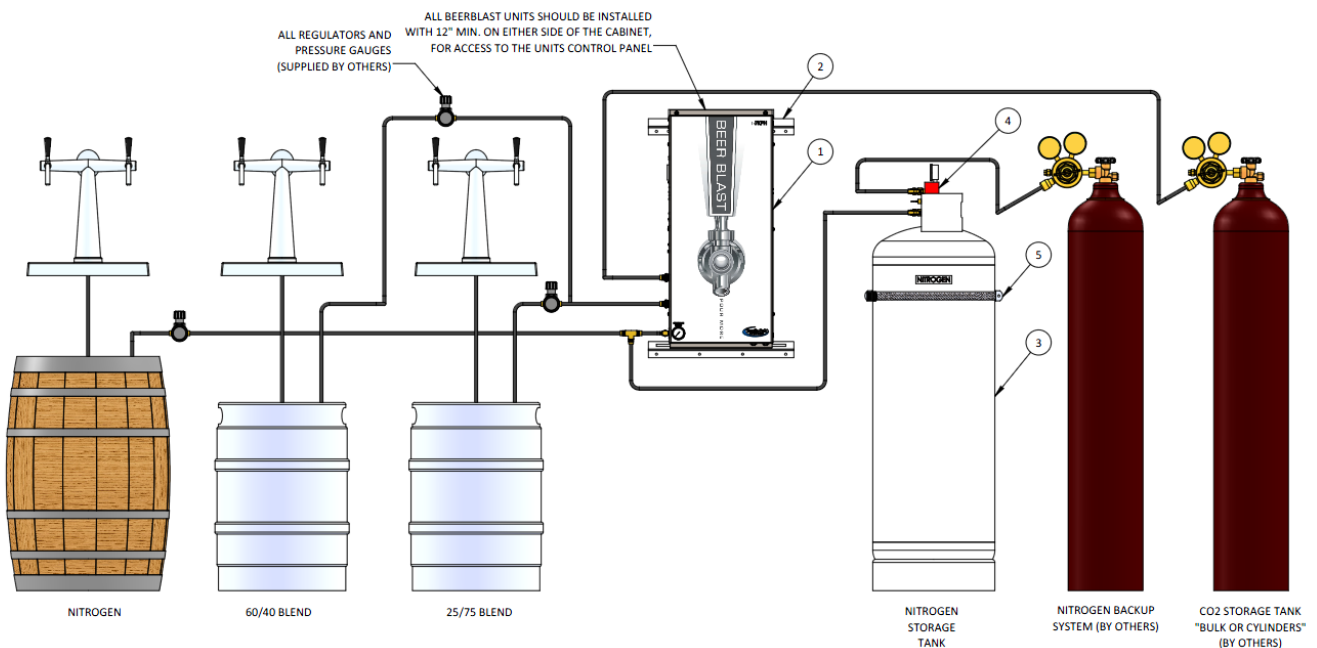

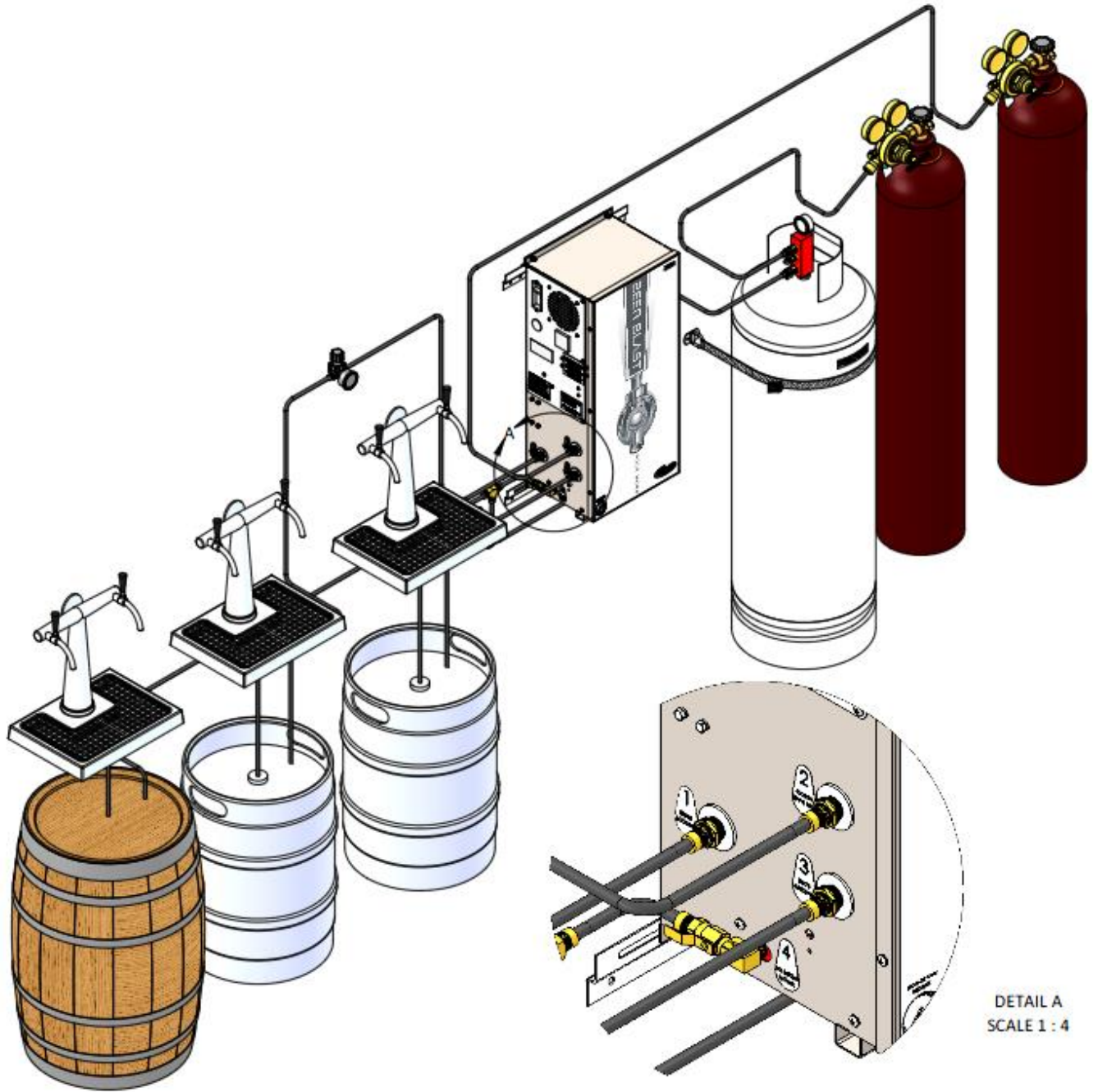

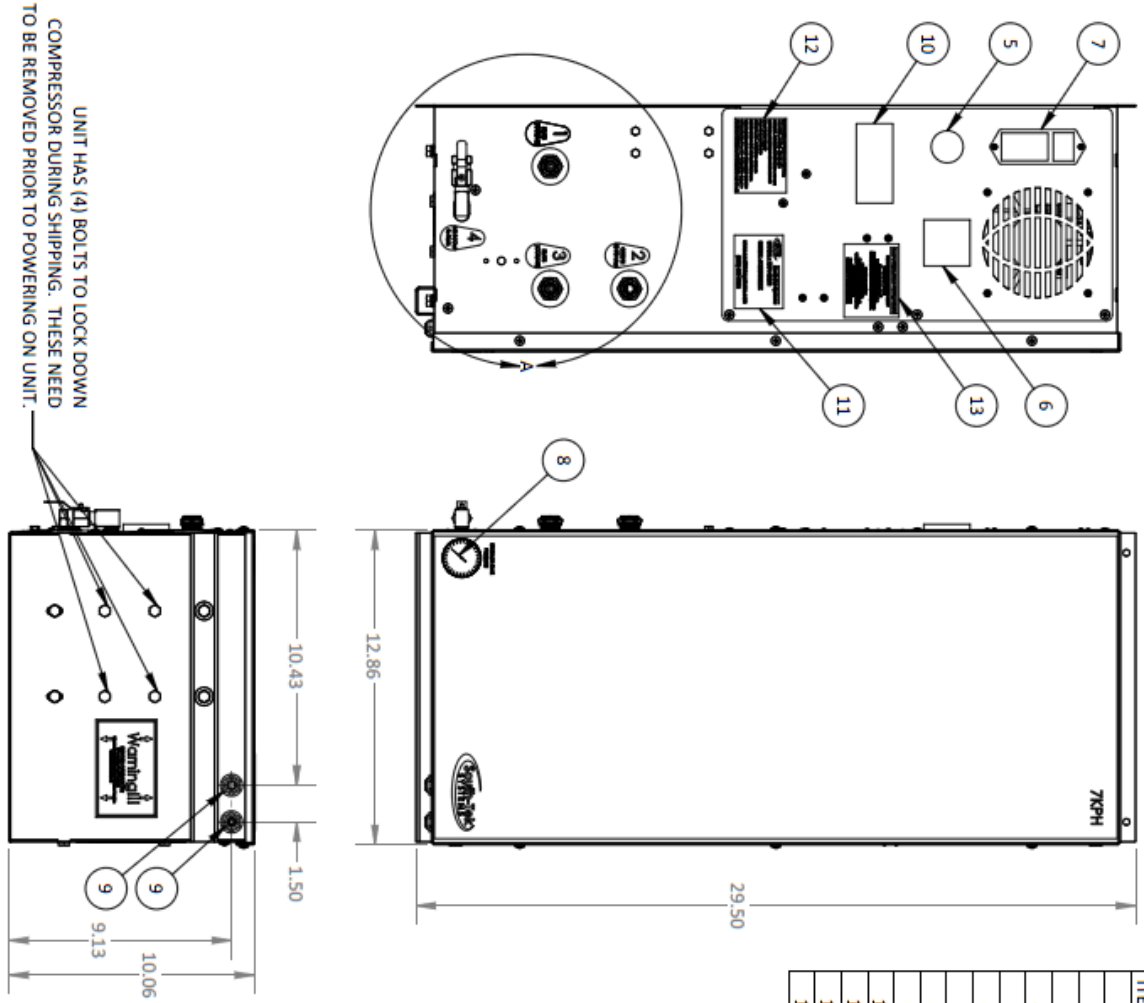

EXTERNAL COMPONENTS		
ITEM #	DESCRIPTION	SERVICE
1	1/4" FPT BALL VALVE	NITROGEN OUT
2	1/4" FPT BALL VALVE (SEE NOTE 1)	60/40 - 70/30 - 50/50 (CO ₂ /N ₂) BLEND OUT
3	1/4" FPT BALL VALVE	25/75 (CO ₂ /N ₂) BLEND OUT
4	1/4" FPT BALL VALVE	CO ₂ IN
5	AUDIBLE ELECTRIC BUZZER	OPTIONAL BLASTOFF ALARM BUZZER
6	PLC	SYSTEM CONTROLLER
7	POWER ENTRY MODULE	SYSTEM POWER SUPPLY
8	0-160 PSIG GAUGE	NITROGEN STORAGE TANK PRESSURE
9	1/4" OD PTC BULKHEAD	DRAIN LINE CONNECTIONS
10	UL 508A OPEN INDUSTRIAL CONTROL PANEL CERTIFICATION LABEL	
11	UNIT SERIAL NUMBER LABEL	
12	ELECTRICAL PANEL SPECIFICATIONS LABEL	
13	BUZZER OR DISPLAY SCREEN WARNING INDICATOR	

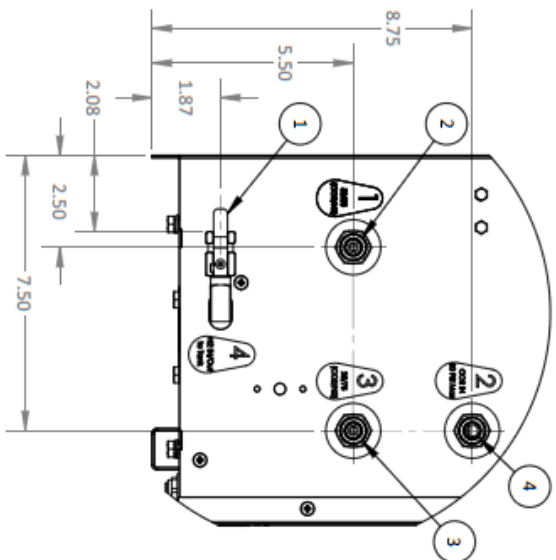

DETAIL A
SCALE 1 : 4

4.6 GAS CONNECTION (BEERBLAST™ 7KPH / N₂-GEN™ 7KPH)

See figures below for panel layout and gas connections. Double-check all connection locations before turning on the system or opening any valves. Note: All BeerBlast™ 7KPH N₂-GEN™ 7KPH models are factory equipped with 1/2" NPT Female connections.

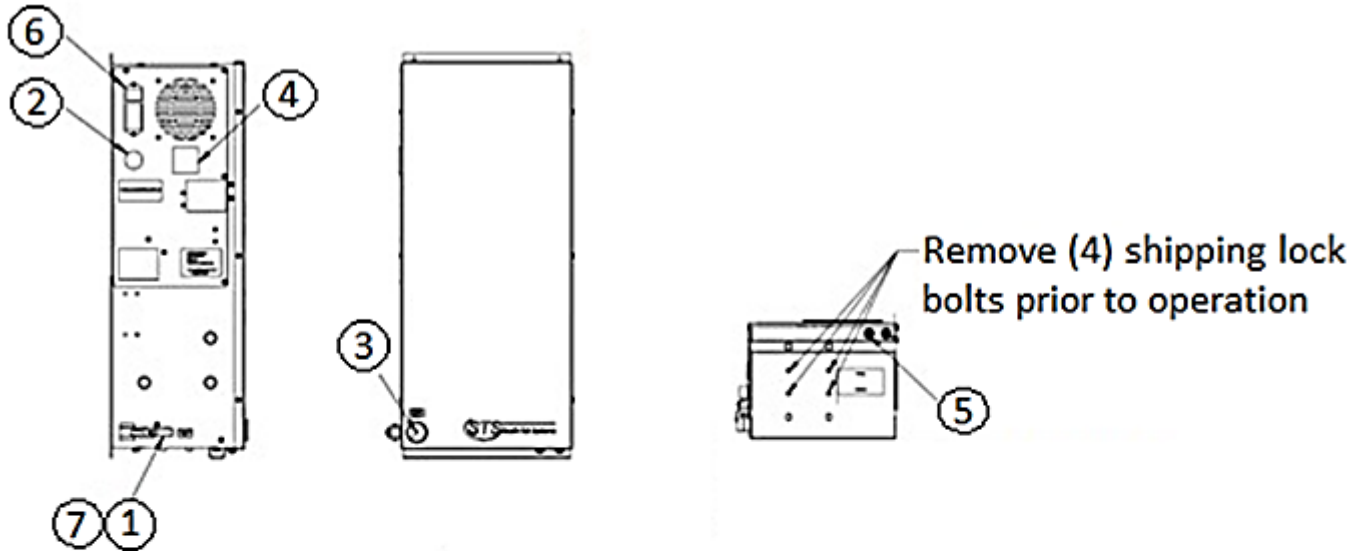

External Components		
Item #	Description	Service
1	1/4" NPT Ball Valve	N2 Out
2	Audible Electrica Buzzer	Audible Alarm
3	1/8" NPT x 1-1/2" 100 PSIG Gauge	N2-Storage Pressure
4	PLC	System Controller
5	1/4" OD Through-Wall Coupling	1/4" OD Drain
6	Power Entry Module, 15 Amp	System Main Power Connection
7	1/4" NPT M x 1/2" NPT F Adapter	N2-Out Adapter for 1/2" Plumbing

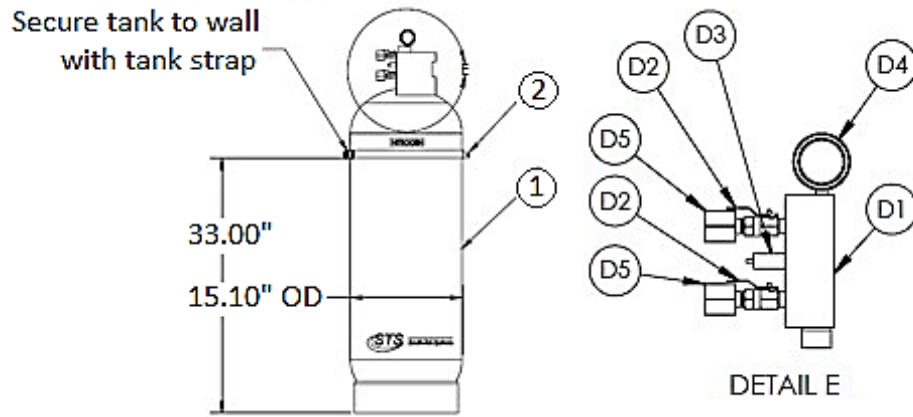

Item #	STS Part #	Description	Qty
1	800-111-FPS	100 # Red Tank w/ Label	1
2	A01-0100-A	100# Tank Strap Assembly	2
3	A01-0100-S-A	Tank Manifold w/0/500" Nozzles	1

Item #	STS Part #	Description	Qty
D1	800-245-A	Tank Manifold	1
D2	124-308	0.250" NPT M x F Ball Valve, Brass	2
D3	124-335-A	0.250" Safety Relief, 115 PSIG	1
D4	124-125	0.250" NPT x 02.000" 1-160 PSIG Gauge	1
D5	524-218	0.500" NPT F x 0.250" NPT M Reducer, Brs	2

Figure 1: 100# N₂ Storage Tank Setup

4.7 INSTALLATION (BEERBLAST™ 14KPH / N₂-GEN™ 14KPH)

The BeerBlast™ 14KPH / N₂-GEN™ 14KPH needs to be installed on a hard flat surface capable of supporting 300+ lbs. There are (4) anchor bolt holes on the support legs that can be used to secure the unit to the floor. It is not required to be anchored, but always follow any site/local codes regarding securing equipment. The unit's back side and right side can be pushed all the way against the wall. Leave at least 6" on the left side of the cabinet for ventilation, but 36" is recommended for access to the control panel (otherwise, the unit will need to be pulled out to read the display). There are also two ¼" OD drain ports on the left side of the cabinet. These can be plumbed to the nearest site drain. The front side of the cabinet requires 36" minimum to gain access to the front door and perform routine maintenance. Leave enough clearance room on the top of the cabinet for gas line connections. The N₂-GEN™ 14KPH will have the first 3 ports plugged as there is not an internal blender.

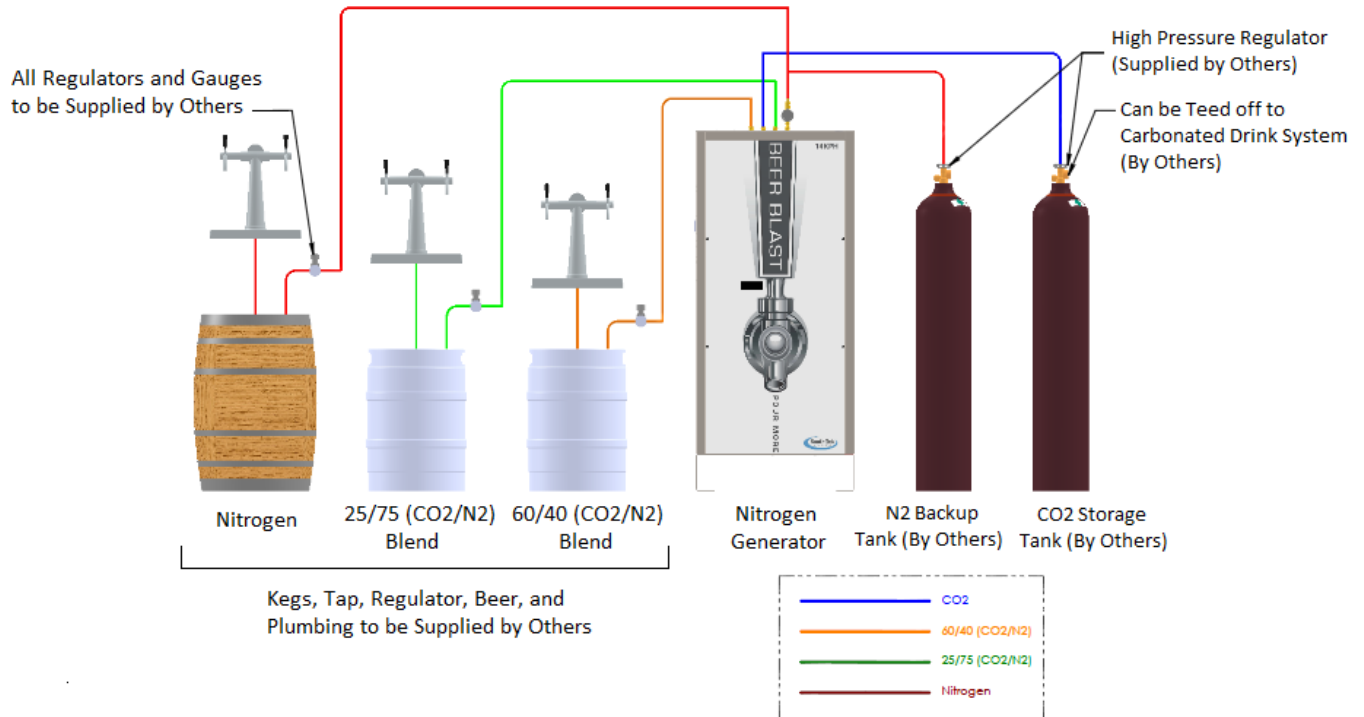

Ports on the upper cabinet are as follows (from left to right): Port 1: 60/40 CO₂/N₂ Blend, Port 2: CO₂ In, Port 3: 25/75 CO₂/N₂ Blend, Port 4, N₂ Out.

First-time use will require an initial pressurization of the internal storage tank. To perform this task, make sure that all gas connections are properly made to the kegs. All gas connection ports are ¼" NPT female.

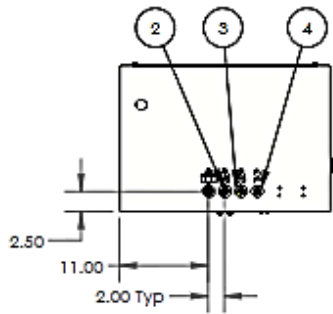

External Components		
Item #	Description	Service
1	1/4" NPT Female Port	Nitrogen Cylinder Backup
2	1/4" NPT Bulkhead	25/75 (CO ₂ /N ₂) Blend Out
3	1/4" NPT Bulkhead	CO ₂ In
4	1/4" NPT Bulkhead	60/40 (CO ₂ /N ₂) Blend Out
5	Audible Electric Buzzer	BlastOff Alarm Signal (Optional)
6	PLC	System Controller
7	Power Entry Module, 15 amp	System Power Supply
8	0-160 PSIG Gauge	Nitrogen Storage Tank Pressure
9	1/4" OD PTC Bulkhead	Drain Line Connections

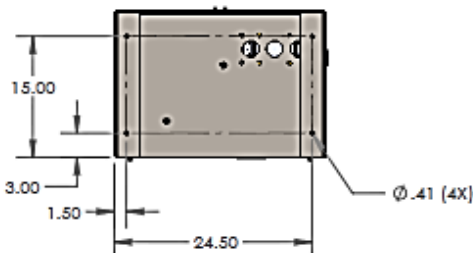
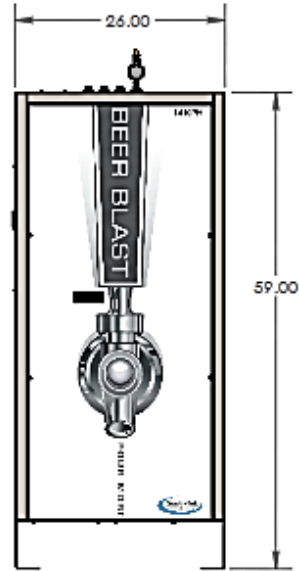
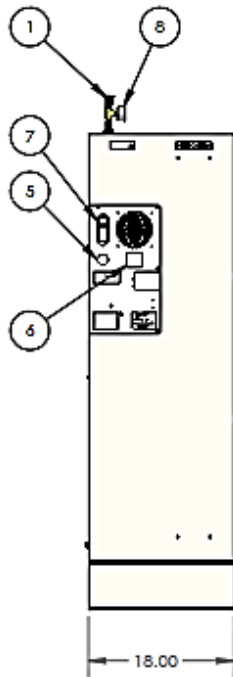
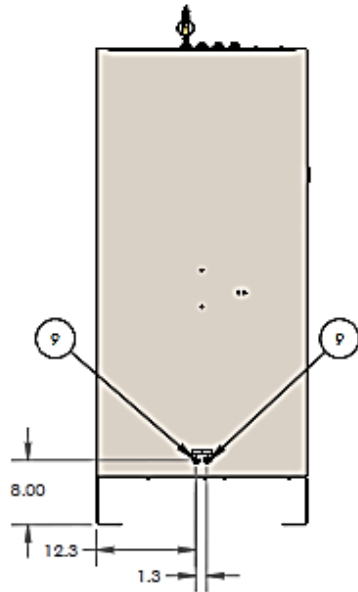

Design Data for BB-14KPH	
Purity	>99.8%
N ₂ Out Pressure	up to 80psi
Electrical	120V / 60Hz / 1Phase
Storage Tank	28 Gallons
Weight	275 lbs

Once the connections are all secure, turn on the power (switch is located externally on the upper left side of the cabinet on the control panel). The initial start-up will require up to 1 hour to fully pressurize the internal storage tank to the correct level. External pressure gauge (at the top coming off the 4th port from the left) can be viewed to verify that the internal storage tank has been filled to 65-75 psig. Once the tank is full, the system will automatically go into a standby mode and is ready for standard operation.

4.8 NITROGEN CYLINDER BACK-UP (BEERBLAST™ 7/14KPH / N₂-GEN™ 7/14KPH)

It is recommended that a backup system be installed in case of any unforeseen complications. A backup N₂ Cylinder tank can be used instead of the generated nitrogen from the BeerBlast™ 7/14KPH / N₂-GEN™ 7/14KPH. It will allow the nitrogen to go through the Blender to achieve the desired results. To install the back-up tank, you will need a cylinder with valve and regulator (regulated to 80 psig). Install the N₂ back-up on the gas line on Port 4 of the BeerBlast™ 14KPH / N₂-GEN™ 14KPH as follows:

1. The N₂ back-up cylinder should have a high pressure regulator and ball valve on the output. It is recommended to have a lockable ball valve and/or labeled for “Backup use only”.
2. If the Back-up system is turned on, the backup will fill the N₂ Storage tank and flow to the BeerBlast™ 14KPH / N₂-GEN™ 14KPH Plus keeping the internal blender pressurized with Nitrogen.

See below for visual piping connections:

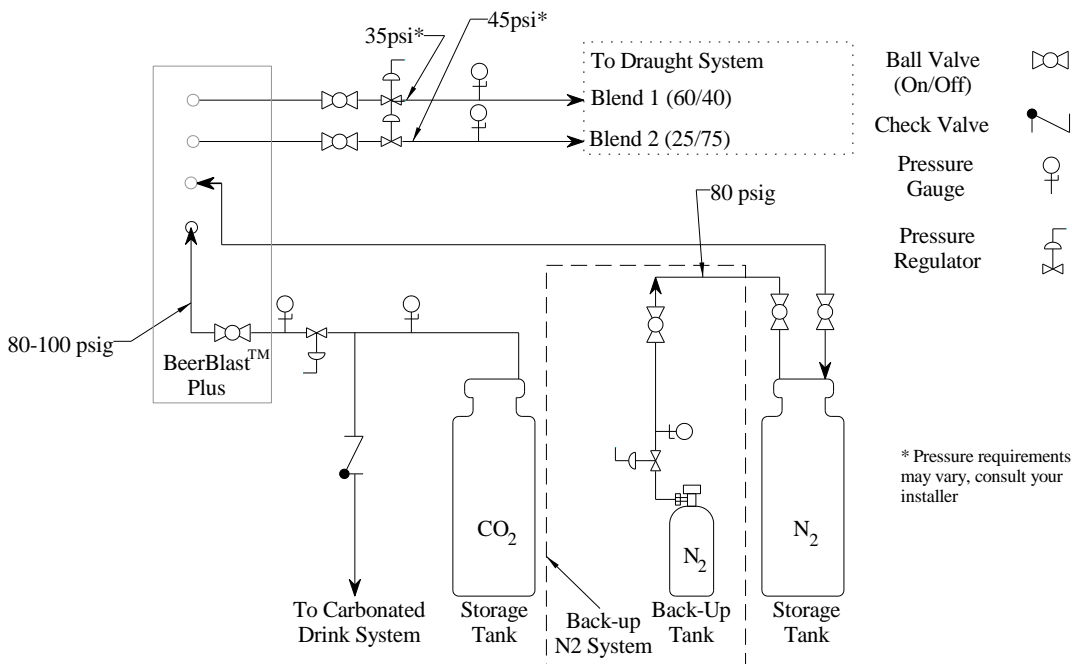

4.9 START-UP PROCEDURES (BEERBLAST™ 7/14KPH / N₂-GEN™ 7/14KPH)

It is necessary to use caution when working with pressurized gas, making sure that all fittings and gas lines are installed correctly. Always leak check every line before using the system.

Note: Line leaks will cause the BeerBlast™ 7/14KPH / N₂-GEN™ 7/14KPH to run excessively, shortening its life and cause excess wear on the compressor.

The installation layout drawings are provided with your system in the documentation package of the system. For electronic copies, please contact your local distributor. Review and make sure the setup installation are followed per the installation layout drawings. Ensure that you follow the correction installation drawing per your system’s design. In some cases, a N₂ Bypass system for pre-filling is required in the installations to meet code.

If your system requirements are more complex, please consult your sales representative or equipment installer for more detailed installation instructions.

1. The BeerBlast™ 7/14KPH / N₂-GEN™ 7/14KPH is supplied with ½” NPT Female inlet and outlet fittings. Make sure to use Teflon tape or similar on all fittings to make sure they don't leak.
2. Connect the BeerBlast™ 7/14KPH / N₂-GEN™ 7/14KPH to the storage tank and then to the beer system.
3. Once connections are made, slowly open the System's On/Off Valve.
 - A. You will hear air rushing through the system and N₂ filling the BeerBlast™ 7/14KPH / N₂-GEN™ 7/14KPH storage tank.
 - B. If you hear a leak or have a bad connection, shut the valve off and make the correction.
 - C. If there is a leak within the unit, remove the cover and locate the issue. If you have to replace any parts, only use factory parts supplied from your distributor or South-Tek Systems. Consult the factory if there are any questions.
4. Once the BeerBlast™ 7/14KPH / N₂-GEN™ 7/14KPH fills the 100# storage tank to 70 PSIG, the system will enter standby – the system's green N₂ Production light will change to orange indicating that the system is in standby. This will shut the air flow off through the generator and eventually shutting off the air compressor once it reaches air tank cutout pressure.
 - A. This will save air and time on your compressor's motor.
 - B. This also prolongs life of nitrogen generator's media and filter life.
 - i. Lesser quality systems have a constant purge flow through their systems which decreases system life and increases the need for maintenance.
5. When you draw N₂ off the system and the tank pressure falls below cut-in pressure (approximately 62 PSIG), the pressure switch will trigger the system back into run mode and start recharging the storage tank automatically. The pressure switch is preset at the factory – no field adjustment is required.

4.10 CHECKING FOR LEAKS

When a leak is suspected, first try to listen for leaks around the connection ports. If a leak is found, isolate the area so that there's no pressure on it. Fix the leaking part and return the system back to operation. If no leak can be heard, turn off the unit and try isolating sections to see if there's a pressure loss. If the BlastOff™ option is included with your unit, the system will alarm indicating that there is a leak in the line. Consult with your installer if you cannot locate the leakage area.

To determine if the leak is within the cabinet:

1. With the unit powered on, close off all output gas. If no ball valve is installed on the output ports, it is recommended to remove the gas lines and install a plug.
2. Allow the system to continue running. Within 1 hour, the system should reach the “Standby” mode.
3. Wait for 5 minutes and if the system remains in the “standby” mode, then the leak is after this point. Check the gas lines exterior to the cabinet all the way back to the keg system.
4. If the unit goes back into “run” mode, the leak is within the cabinet. Check all the lines going to the blender and back to the tank.

To find the leak within the cabinet:

1. Open the front cabinet door and locate the N₂ storage tank.
2. Close off the output ball valve from the tank (upper ball valve on the red manifold).
3. Watch the exterior gauge above the cabinet for 60 seconds. If you see the pressure dropping, the leak is somewhere between the output ports, to the blender (if one is present), and back to the closed off ball valve on the tank. Fill and/or listen for leaks and fix them once found. If the pressure is not dropping go to the next step.
4. With the unit still running, close off the input ball valve to the tank (lower ball valve on the red manifold).
5. Within 5 minutes, the system should go into “Standby” Mode. If it doesn't, contact your local provider/installer for further assistance.
6. Once in “Standby” mode, wait 60 seconds. After 60 seconds, the system should remain in “standby” mode. If it doesn't, leak is somewhere between the check valve and the output ball valve on the tank.
7. If the system remains in standby, contact your local provider/installer for further assistance.

4.11 ACCESS CONTROLS

The built in controller is fully programmed to function without requiring the user to input any values. Do not attempt to modify the program or the warranty will be voided. In case of the program failure, first attempt to cycle the power to the system. If that does not work, please contact your provider for further instructions.

4.12 STARTING THE SYSTEM

To start the system, turn on the power switch and make sure any valves to the gas lines are in the open position.

4.13 STOPPING THE SYSTEM

To stop the system, close off any valves on the gas lines. Powering down the system is not necessary.

5 SYSTEM USAGE

5.1 INSTRUCTIONS

The BeerBlast™ 7/14KPH / N₂-GEN™ 7/14KPH is intended to be used to generate Nitrogen, and provide a CO₂/N₂ blend to push beer out of the keg. Follow the installation instructions above and only use in an approved environment. The generator generates enough nitrogen to push 14 kegs per hour. Make sure that proper regulators, cooler temperature, and line temperatures are maintained, otherwise you will not be able to effectively push beer from the keg. Please consult with your local provider for questions not answered in this manual.

The system is design for 24 hour operation, but routine maintenance on the filters must be performed. See section “System Maintenance” for detail maintenance instructions.

5.2 ALARM NOTIFICATION

Filter Alarm:

All BeerBlast™ 7/14KPH / N₂-GEN™ 7/14KPH comes standard with a “Filter Alarm” notification. The controller will display a “Fit Alm” message in red when the filter change is overdue. It is recommended that the filters be changed once every year or every 1000 hours, whichever comes first. See section “System Maintenance” for detail maintenance instructions.

BlastOff™ - Leak Detection System Alarm

An optional feature that can be included with the system is the BlastOff™ - Leak Detection System. It is a patented system when installed into the BeerBlast™ 7/14KPH / N₂-GEN™ 7/14KPH detects line leaks within the downstream gas lines from the N₂ Generator to the kegs. Line leaks could be due to a keg not being tapped correctly, a beer gas line leak or fitting therein failing, etc. These leaks are potential safety hazards, they can cause the CO₂ to deplete quickly, and could cause your BeerBlast™ 7/14KPH / N₂-GEN™ 7/14KPH to run in excess (decreasing the life of the unit).

Once a leak has been detected, the BlastOff™ set to initiate a buzzer, displays “B.Off” in red on the controller screen, and shuts off the BeerBlast™ 7/14KPH / N₂-GEN™ 7/14KPH until the problem has been remedied. To reset the BlastOff™, simply turn off the BeerBlast™ 7/14KPH / N₂-GEN™ 7/14KPH and turn it back on. The BeerBlast™ 7/14KPH / N₂-GEN™ 7/14KPH can be ordered with the BlastOff™ System Factory installed or the system can be retrofitted in the field. Some rewiring is required to field install.

Never reset repeatedly; if the BlastOff™ goes off daily, there is a real potential issue. Consult your installer for a solution. The label below and the Logo above will be on your BeerBlast™ 7/14 KPH or N₂-GEN™ 7/14 KPH if factory installed.

Buzzer or Red Light Warning

This unit is equipped with **The BlastOff™ - Leak Detection** feature. If the red light and buzzer are on, you may have a leak in one of the beergas lines or one of your kegs may not be properly tapped, causing beergas leaks. **Note:** Turn off this unit's on/off rocker switch and check for leaks. If none are found, leave the unit turned off and contact your service company. Once the leak has been fixed, turn the BeerBlast™ on/off rocker switch back on to resume normal operation.

6 SYSTEM MAINTENANCE

Whenever doing any maintenance to the system, make sure to power down the system. Remove the front cover to gain access to the filters.

Annual Filter replacement kit part # [FRP-001](#)

Air Pre-Filter

The integrated Air Compressor has an air intake pre-filter. It is design to prevent particles from entering into the compressor housing and damaging internal components. This filter needs to be replaced once per year or every 1000 hours, whichever comes first. To do so, remove the pre-compressor filter cap by twisting it clockwise. Remove the old element and use a clean dry cloth to clean the filter bowl before installing the new element.

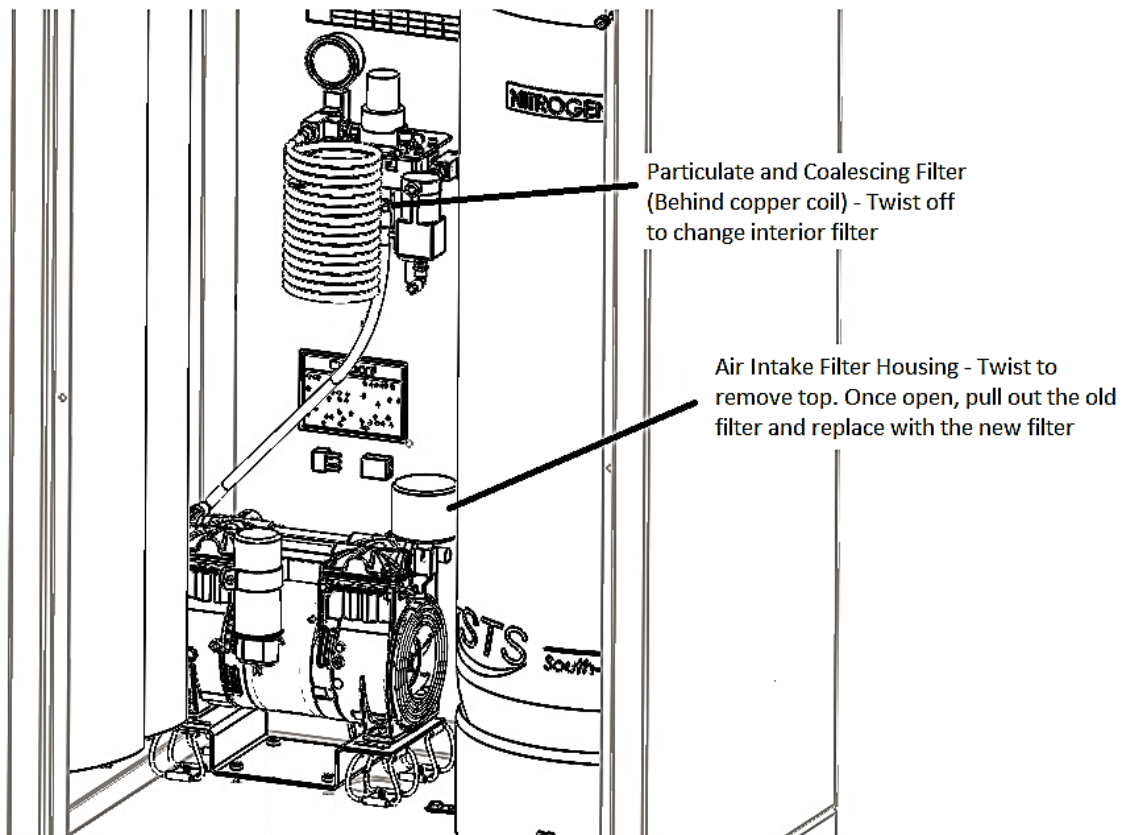

Particulate and Coalescing Filter

The particulate and coalescing filter after the air compressor is designed to capture particulate and moisture prior to entering the rest of the system. These filters need to be replaced once per year or every 1000 hours, whichever comes first. To do so,

1. Make sure there is no pressure on the filter bowls. The gauge after the filter bowl will read 0 PSIG to indicate that there is no pressure on the bowl.
2. Unscrew the filter bowls by turning them counter clockwise.
3. Once the filter bowls have been removed, rinse any debris out of the bowls with warm water.
4. Dry the bowls with a clean dry cloth and replace the old O-rings with the ones provided in the kit.
5. Using a Philips-Head screwdriver, remove the particulate element and replace.
6. The coalescing element can be removed by turning it counter-clockwise with your hand; then replaced with the new element in the reverse order.
7. Once both elements have been replaced, bowls have been cleaned and O-rings replaced, the bowls can be screwed back in to their corresponding filter housings.

Once all the filters have been replaced, press the filter reset button on the electrical panel. Put the front cover back on the cabinet and the unit can be powered up again. Once powered up, you should hear the air compressor turn on and the BeerBlast™ 7/14KPH / N₂-GEN™ 7/14KPH will be producing nitrogen.

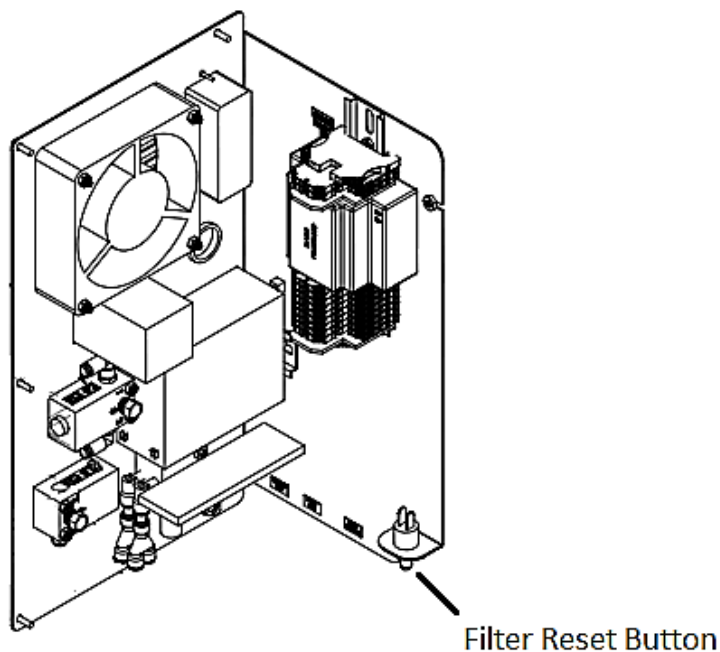

7 KEY CONTACTS

Contact your local provider/installer for any questions with the performance and/or maintenance of the system. They will be best suited to answer your questions and your quickest solution on any issues you may have.

8 FAQs

8.1 POWER ISSUES

If the BeerBlast™ 7/14KPH / N₂-GEN™ 7/14KPH does not have power, the production and storage of nitrogen will become apparent once the storage pressure drops. The taps will begin to pour slowly or not at all.

1. Check the power cord
2. Has the building's circuit breaker or GFCI tripped? Locate the breaker and reset. If the breaker continues to trip, you may have that circuit overloaded.

8.2 PRESSURE ISSUES

Whether you are using a BeerBlast™ 7/14KPH / N₂-GEN™ 7/14KPH with an integrated gas blender or an N₂-GEN™ 14KPH with an external gas blender, you have to have both gases (N₂ and CO₂) available with pressures over 40 psig. Blenders will shut down output if either gas is not present over 40 psig.

The BeerBlast™ 7/14KPH / N₂-GEN™ 7/14KPH will produce and store nitrogen at 70 (+/-3) psig. Once the storage tank reaches 70 (+/-3) psig, the system will go into Stand-By Mode. When the pressure drops by about 7-10 psig, the system should go into Operation Mode and begin to refill the storage. If you are out of the specifications, we need to determine where the issue is. Contact the manufacturer or factory trained technician.

CO₂ Pressure Check:

If you have a BeerBlast™ 7/14KPH / N₂-GEN™ 7/14KPH, look at your CO₂ regulator pressure gauge. It should read between 80 and 100 psig. If it is lower, check the CO₂ Storage tank to see if it needs refilling or if the pressure regulator needs adjustment. The pressure going into the BeerBlast™ 7/14KPH / N₂-GEN™ 7/14KPH is recommended to be set at 80 psig.

Nitrogen Pressure Check:

Look at the pressure gauge on the top of the cabinet. It should be between 50 and 80 psig. If the pressure is low, a few things need to be checked.

- Check the power.
- Check for leaks throughout the system. Refer to section on **Checking for Leaks.**

Pressure Regulation Check:

Lastly, if the CO₂ and N₂ are both present and the blender is outputting gas, it's possible a regulator is malfunctioning or needs adjustment. The mixed gas coming from the blender should be between 40-80 psig (dependent on the N₂ and CO₂ pressures going into the blender). A primary regulator is usually installed on the output lines coming from the BeerBlast™ 7/14KPH / N₂-GEN™ 7/14KPH. The primary regulator is there to "step down" the available pressure to the kegs. There are typically secondary regulators located further downstream on the mixed gas lines going to the kegs. The secondary regulators are there to individually tune each keg. Some beers require more/less pressure and regulating each keg individually will allow the beer pouring to be optimized.

If the BeerBlast™ 7/14KPH / N₂-GEN™ 7/14KPH is operating correctly, then the restaurant/pub should contact their Draft Beer System Technician to adjust the regulators for optimal performance.

8.3 GAS LEAKS

As with any gas system, only use a spray bottle on non-electrical equipment to find leaks. Fix or replace leaking fittings or old hose. Push-to-connect fittings will show bubbles and typically have up to a 5ccm acceptable leakage rate. Contact your local provider/installer for help.

8.4 TEMPERATURE ISSUES: VERY COMMON ISSUE

Consistent beer temperatures are crucial to a good pour. Typically, the beer in the keg should be kept between 36-38 degrees F. It should be sent from the keg to the tap at the same temperature. If there is a change in temperature of the beer between the keg and the glass, then you may experience foaming. Take the temperature of the beer at the glass and if it is above 40 degrees F, you may need to see if the Glycol line cooling system is operating properly. If a keg(s) is warm, change to a properly chilled keg and resume. Contact your refrigeration expert if you have temperature issues, the BeerBlast™ 7/14KPH / N₂-GEN™ 7/14KPH does not influence temperature.

8.5 BLASTOFF™ - LEAK DETECTION SYSTEM:

“There is an alarm sounding in the BeerBlast™ 7/14KPH / N₂-GEN™ 7/14KPH and the control panel has B.Off illuminated on the side panel of the unit.”



If you hear the alarm and the “B.Off” is displayed on your unit, it means that it is equipped with “*The BlastOff™ - Leak Detection*” feature. If the buzzer is on, there may be a leak in one of the beergas lines, regulators, or one of the keg couplings may not be properly seated, causing beergas leaks. Note: Turn off this unit’s on/off power switch and check for leaks. If none are found, leave the unit turned off and contact your Draft Beer System Technician. Once the leak has been fixed, turn the BeerBlast™ 7/14KPH / N₂-GEN™ 7/14KPH on/off rocker switch back “On” to resume normal operation. By turning the system power off, then back on, this will reset the BlastOff™ automatically.

APPENDIX A: WARRANTY

The BeerBlast™ 7/14KPH / N₂-GEN™ 7/14KPH System is warranted against any defects in workmanship and materials for 12 months (or 1000 hours) from the date of shipment from South-Tek Systems, whichever comes first. The purchaser has the liability to ensure that the system is fully inspected upon delivery and shall contact the appropriate shipping company to make any claims on damaged goods due to transit within that shipping company's policies. If the system is received with defects that are not due to shipping, a written claim should be submitted to South-Tek Systems within 1 week of receiving the shipment. South-Tek Systems can deny all other claims at their discretion.

All warranty work shall be done at a South-Tek System facility or at a BeerBlast™ 7/14KPH / N₂-GEN™ 7/14KPH Authorized Service Center. Only factory trained and authorized personnel are covered under warranty. Any part that is returned / repaired / replaced under warranty may be remanufactured or changed to a different specification at the factory's option. Any work performed by an unauthorized person/company or usage of non-factory parts, may void all warranties to the product.

Any item not manufactured by South-Tek may carry its own warranty from its manufacturer and will be warranted by that manufacturer. All parts that need to be returned should be announced. Any item(s) that is returned to South-Tek Systems without an RMA number (return authorization number) may be denied and returned to the sender. Contact the factory for RMA #'s, prior to return shipment.

South-Tek Systems is not liable for damages caused by normal wear and tear, water, fire, erosion, corrosion, explosion, misuse, oil/gas vapors or unauthorized modifications. South-Tek Systems is also not liable for any losses (including CO₂), damages, or cost of delays, including incidental or consequential damages. There are no warranties or guarantees, expressed or implied, including the warranties of merchantability or fitness for a particular purpose or use, other than those warranties expressed herein.

For Claims, contact South-Tek Systems LLC at:

tel (910) 332-4173 or toll free (888) 526-6284, fax (919) 847-0255

Email: support@southteksystems.com

Or write to:

South-Tek Systems,
Warranty Claims,
2940 Orville Wright Way,
Wilmington, NC 28409

-----Last Page-----